



ET-7016

PET-7016

Ethernet I/O Module with 2-channel Strain Gauge Inputs,
2-channel DI, 2-channel DO

Features

- Built-in Web Server
- Web HMI
- Support for both Modbus TCP and Modbus UDP Protocols
- Communication Security
- Dual Watchdog
- Wide Operating Temperature Range: -25 to +75°C
- I/O Pair Connection
- Built-in I/O
 - Strain Gauge Input: 2 Channels
 - DI/Counter: 2 Channels
 - DO: 2 Channels



Introduction

The ET-7016/PET-7016 is a strain gauge module with 2 analog input channels, 1 excitation voltage output channel, 2 digital input channels and 2 digital output channels module. It provides various programmable analog input inputs (+/-1 mV, +/-50 mV, +/-100 mV, +/-500 mV, +/-1 V, and +/-2.5 V) and supports full-bridge, half-bridge, and quarter-bridge. The range for each analog input is allowed to be configured individually. Excitation voltage output can be in the range of 0 ~ 10 V with a 60 mA driving efficiency. Digital outputs can also be set as alarm outputs. The ET-7016/PET-7016 can also provide long-distance strain gauge measurement that compensates for the loss of voltage resulting from long-distance measurements.

System Specifications

Model	ET-7016	PET-7016
Software		
Built-in Web Server		Yes
Web HMI		Yes
I/O Pair Connection		Yes
Communication		
Ethernet Port	10/100 Base-TX with Auto MDI/MDI-X	
PoE	-	Yes
Protocol	Modbus TCP, Modbus UDP	
Security	ID, Password and IP Filter	
Dual Watchdog	Yes, Module (0.8 seconds), Communication (Programmable)	
LED Indicators		
L1 (System Running)		Yes
L2 (Ethernet Link/Act)		Yes
L3 (Ethernet 10/100 M Speed)		Yes
PoE Power	-	Yes
2-Way Isolation		
Ethernet	1500 Vdc	-
I/O	2500 Vdc	2500 Vdc
EMS Protection		
ESD (IEC 61000-4-2)	±4 kV Contact for Each Terminal and ±8 kV Air for Random Point	
EFT (IEC 61000-4-4)	±4 kV for Power Line	
Power		
Reverse Polarity Protection		Yes
Powered from Terminal Block	Yes, 10 ~ 30 VDC	Yes, 12 ~ 48 VDC
Powered from PoE	-	Yes, IEEE 802.3af, Class1
Power Output	-	-
Consumption	2.9 W (Max.)	3.2 W (Max.)
Mechanical		
Dimensions (L x W x H)	123 mm x 72 mm x 35 mm	
Installation	DIN-Rail or Wall Mounting	
Environment		
Operating Temperature	-25 to +75°C	
Storage Temperature	-30 to +80°C	
Humidity	10 to 90% RH, Non-condensing	

I/O Specifications

Strain Gauge Input		
Channels	2 (Differential)	
Type	+/-15 mV, +/-50 mV, +/-100 mV, +/-500 mV, +/-1 V, +/-2.5 V, +/-20 mA, 10 ~ 20 mA, 4 ~ 20 mA	
Strain Gauge Type	Full-Bridge, Half-Bridge, and Quarter-Bridge	
Individual Channel Configuration	Yes	
Resolution	16-bit	
Sampling Rate	10 Samples/Second (Total)	
Accuracy	+/-0.05%	
Zero Drift	+/-0.5 μ V/ $^{\circ}$ C	
Span Drift	+/-25 ppm/ $^{\circ}$ C	
Overvoltage Protection	30 Vdc	
Input Impedance	Voltage Input: >400 k Ω , Current Input: 125 Ω	
Common Mode Rejection	150 dB min.	
Normal Mode Rejection	100 dB	
Excitation Voltage Output		
Channels	1	
Output Range	0 ~ 10 V	
Max. Output Load Current	60 mA	
Accuracy	+/-0.05% of FSR	
Drift	+/-50 ppm/ $^{\circ}$ C	
Power-on Value	Yes	
Digital Input/Counter		
Channels	2	
Contact	Wet	
Sink/Source (NPN/PNP)	Sink/Source	
Off Voltage Level	+1 Vdc Max.	
On Voltage Level	+3.5 Vdc ~ +50 Vdc	
Counters	Channels	2
	Max. Count	4,294,967,295 (32-bit)
	Max. Input Frequency	100 Hz
	Min. Pulse Width	5 ms
Overvoltage Protection	70 Vdc	
Digital Output		
Channels	2	
Type	Isolated Open Collector	
Sink/Source (NPN/PNP)	Sink	
Max. Load Current	700 mA/Channel	
Load Voltage	+5 Vdc ~ +50 Vdc	
Overvoltage Protection	60 Vdc	
Overload Protection	1.4 A	
Short-circuit Protection	Yes	
Power-on Value	Yes, Programmable	
Safe Value	Yes, Programmable	

Wire Connections

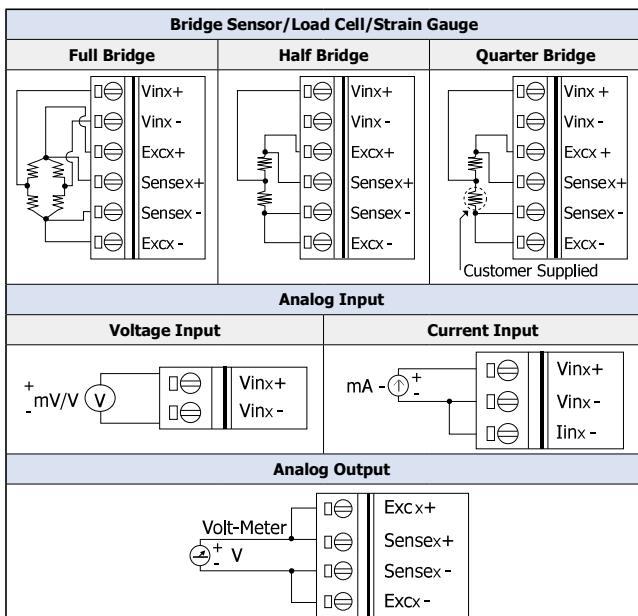

Pin Assignments

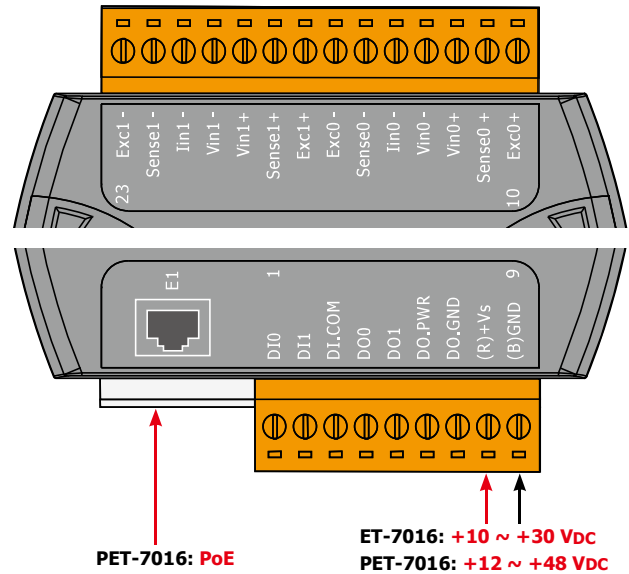

Excitation Voltage

Strain Gauge	Quarter-Bridge	Half-Bridge	Full-Bridge
120 R	7.0 V	7.0 V	3.5 V
350 R	10 V	10 V	10 V

Ordering Information

ET-7016 CR	Ethernet I/O Module with 2-channel Strain Gauge Inputs, 2-channel Digital Input, 2-channel Digital Output (RoHS)
PET-7016 CR	PoE Ethernet I/O Module with 2-channel Strain Gauge Inputs, 2-channel Digital Input, 2-channel Digital Output (RoHS)

Digital Input/Counter	Readback as 1	Readback as 0
	+10 ~ +50 Vdc	OPEN or <4 Vdc
Sink		
Source		

Output Type	ON State Readback as 1	OFF State Readback as 0
Drive Relay		
Resistance Load		