

EtherCAT



ECAT-2611

EtherCAT Slave to Modbus RTU Slave Gateway

Features

- Powerful MCU handles efficient network traffic
- 2 x RJ-45 EtherCAT Connectors
- Allows system integrators to retro-fit older automation devices into modern EtherCAT communication structures
- Requires no hardware or software changes to be made to the connected device
- Compatible with all PLCs with EtherCAT support
- Performs complete serial protocol conversion, no PLC function blocks required
- Supports maximum 256 WORD Input and 256 WORD Output Data
- Supports Serial Port interface
 - Supports Modbus RTU (Slave) Protocol
 - Supports RS-232/422/485 Port
 - Supports Maximum Baud Rate 115200 bps
 - Supports Modbus Function Code 03/04/06/16



Introduction

The ECAT-2611 is a proven and trusted protocol converter gateway module that allows you to seamlessly inter-connect devices between EtherCAT and Modbus RTU networks. The ECAT-2611 acts as a Slave on both networks, allowing I/O data to be transferred between the two networks.

The ECAT-2611 provides a data exchange buffer that allows two different systems (EtherCAT Master and the Modbus RTU Master) exchange data easily and faster for more diverse applications.

Hardware Specifications

Network Interface	
Protocol	EtherCAT
RJ-45 Port	RJ-45 x 1 Distance between Stations: Max. 100 m (100BASE-TX) Data Transfer Medium: Ethernet/EtherCAT Cable (Min. CAT 5e)
Communication Interface	
Protocol	Modbus RTU (Slave)
Serial Interface	The RS-232, RS-422 and RS-485 cannot be used simultaneously ▶ TxD, RxD, GND ▶ TxD+, TxD-, RxD+, RxD- ▶ Data+, Data-
RS-232	
RS-422	
RS-485	
Power	
Input Voltage Range	+12 ~ +48 Vdc
Power Consumption	0.1 A @ 24 VDC
Protection	Power reverse polarity protection
Connector	3-Pin Removable Terminal Block (5.08 mm)
Mechanical	
Dimensions (W x L x H)	33 mm x 127 mm x 99 mm
Installation	DIN-Rail Mounting
Casing	Plastic
Environment	
Operating Temperature	-25 ~ +75°C
Storage Temperature	-30 ~ +80°C
Relative Humidity	10 ~ 90% RH, Non-condensing

Pin Assignments

COM1 (Console Port)				
Pin Assignment	Terminal	No.	Pin Assignment	
--	01		06	--
RxD	02		07	--
TxD	03		08	--
--	04		09	--
GND	05			

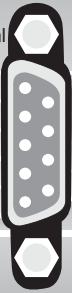

COM2/COM3 (Modbus RTU)		
Terminal No.		Pin Assignment
COM2		TxD+/D+
		TxD-/D-
		RxD+
		RxD-
COM3		N/A
		ISO.GND
		TxD
		RxD

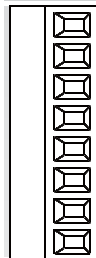

EtherCAT Interface	
Terminal No.	Pin Assignment
	F.G.
	GND(-)
	PWR(+)
	IN
	OUT

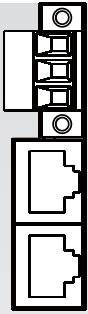

Applications

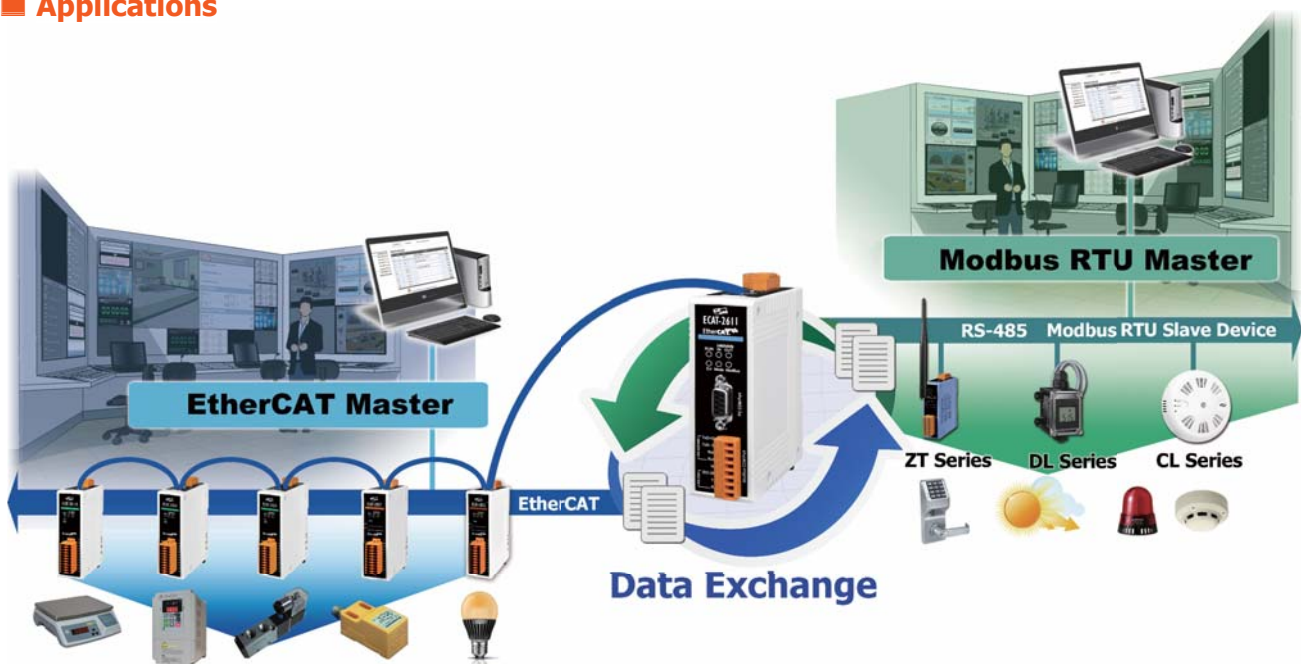

Dimensions (Units: mm)

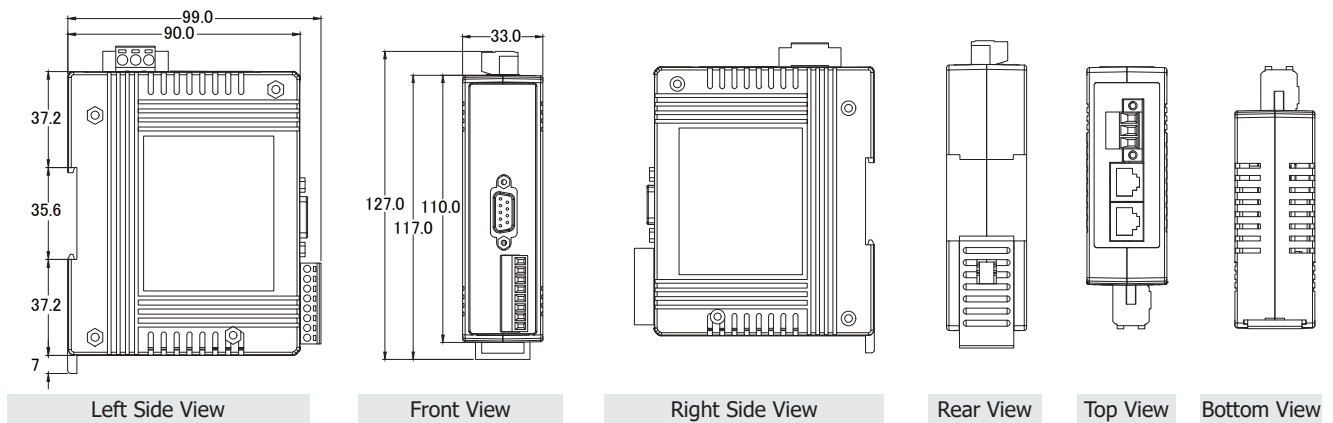

Ordering Information

ECAT-2611 CR	EtherCAT Slave to Modbus RTU Slave Gateway (RoHS) Includes CA-0915 (DB9 Male to DB9 Female Cable, 1.5 M)
---------------------	---